

Innovative Drive Systems

for the highest demands

ATLANTA



A TECHNOLOGY LEADER IN HIGH DEMAND

FOR ALMOST 100 YEARS
WE MANUFACTURE DRIVE SYSTEMS
AT THE HIGHEST LEVEL

As a medium-sized family company which specializes in the development, construction and production of high quality drive systems, we have proved ourselves for over 80 years developing excellent solutions in the field of drive technology. As an established manufacturer of drive technology, we produce in Bietigheim-Bissingen high-qua-

lity and low-backlash gearboxes, racks, gears and linear actuators. Constant new development ensures that we can react flexibly to complex challenges in drive technology. In addition to our extensive catalogue range, we also offer custom solutions in special gearboxes and special individual parts.

Engineering and Production Made in Germany

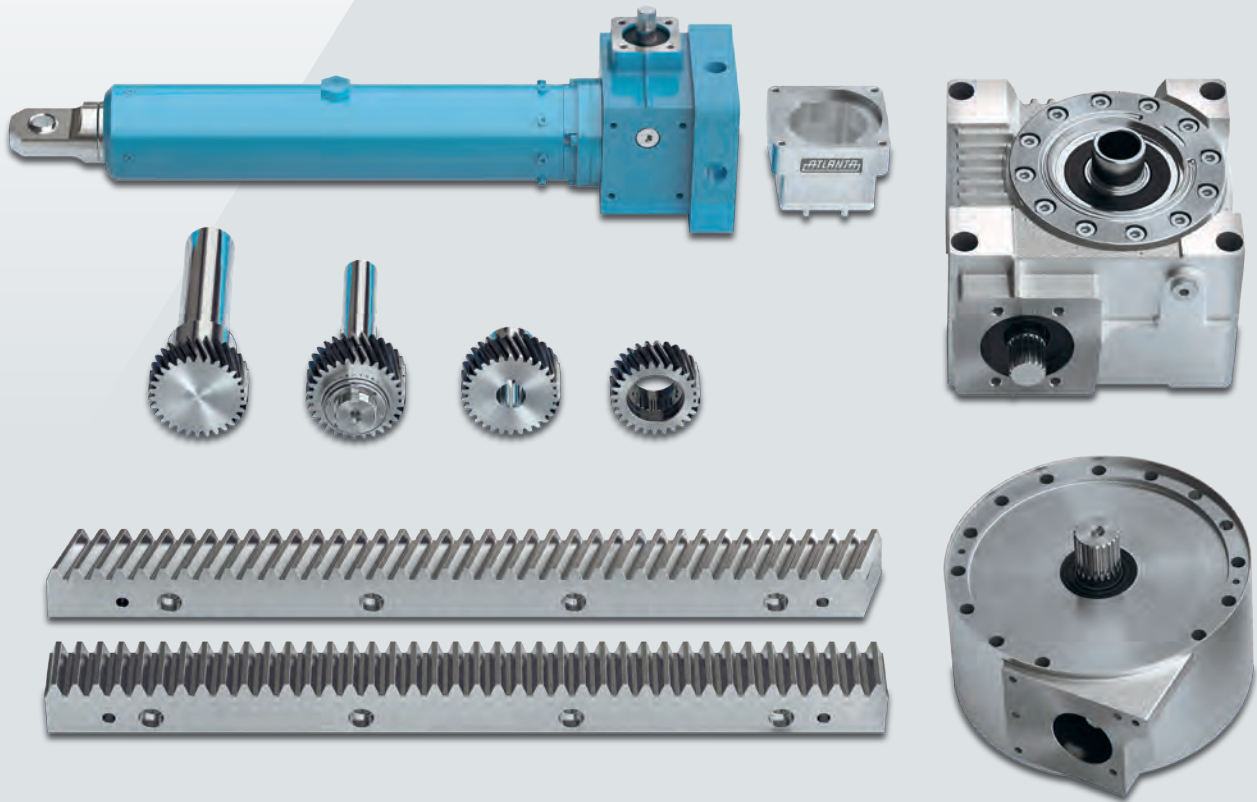

Racks and Pinions

Over 350 different types of high-quality racks.

With our four classes of racks, almost all conceivable applications can be optimally realized and thus find the right solution for every application.

Servo Worm Gear Units

One idea, three variations. all possibilities.

Our family of servo worm gearboxes represent one of the widest ranges of hollow shaft right angle servo gear units currently available on the market.

Linear Actuators

Controllable high performance in every situation.

The high-performance screw jack gearboxes as a unit of linear movement, for all applications where highest precision, high speeds and high duty cycle is required.

Special Gear Units and Special Parts

Innovative solutions for complex situations in drive technology.

We offer more than just the standards. Our specialists show their strengths especially with special, complex problems of drive technology - from consulting and conception to construction and production.



A PRODUCTION THAT GROWS WITH ITS TASKS

HIGH QUALITY WAS
OUR GREATEST STRENGTH
SINCE ALMOST 100 YEARS AGO

The consistently high quality of all ATLANTA products has always been and always will be the driving force behind our work. The ISO 9001:2015 certification is the basis for the high standard of ATLANTA quality assurance, both in the standard area and for customer-specific solutions.

The durability and reliability of our drive systems are highly valued by our long-standing customers worldwide. With a continuous improvement process for all our products, we ensure that you can always trust in the future "Made by ATLANTA".

„OUR PRODUCTS OFFER OUR CUSTOMERS AN INCOMPARABLE ADDED VALUE THAT WE KNOW HOW TO PROVE EVERY DAY ANEW “

Andreas Kunz | Sales Manager



Qualified staff and modern production technologies are the guarantee for our success

With our qualified staff and modern, broad established production facilities we guarantee very high manufacturing standards and the supply of drive systems in premium quality. Through our many years of experience with different processing methods we can provide you with tailor-made constructions and flawless products. We would be happy to take on more steps for you, for example with our highly modern transmission assembly – always individually tailored, of course to your needs.





WITH THIS SERVICE NO WISHES ARE UNFULFILLED

We are with you from the first idea to installation in your machine and beyond.

With our subsidiary companies in the USA, China and France as well as 23 agencies in all industrialized countries of the world, we are present for our customers worldwide.

Project-related advice, high availability of the required items and short deliver times make us flexible and reliable partner in the world of drive technology.



Our service starts with the first conversation with you as customer. After all, it is about optimally matching our service to your individual needs.

We always work on a par with our customers: An intensive cooperation in all project phases creates the basis for efficiency and success. Our national and international customers alike appreciate the sound and professional advice of our specialists. In addition, we offer fast and reliable support for all technical questions and issues to our products and create for you the complete design of your drive system.



Early advice at the beginning of production planning



Decades of technical know-how from our technicians



Our experts are happy to advise you



Photo: Durr AG

With a perfectly coordinated product portfolio, we develop and implement industry and customer-oriented drive solutions. The constant improvement processes of ATLANTA products guarantee the longevity and reliability of our products for almost 100 years.

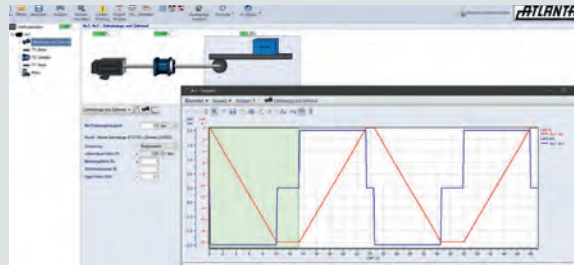

With the SERVOSoft® design software, we determine the most technically and economically advantageous solution for your drive system. The database contains all ATLANTA racks, pinions and gearboxes. This makes the exact power flow of the individual parts within an application transparent and thus enables a precise calculation of your entire system.



INDUSTRIES AND APPLICATIONS THAT TRUST ATLANTA

Whether offshore energy production or the measurement of watchmaking tools, we make a contribution to your success.

Long-term relationships and partnerships on a par characterize the cooperation with our customers. We design and develop innovations for the future with companies from different industries. Where quality standards are highest, our employees demonstrate their competence and

many years of experience in the field of drive technology. Every industry brings its own challenges and requirements. That's why we offer you industry-specific solutions that are individually tailored to you. Get in touch with our experts.

Robotics

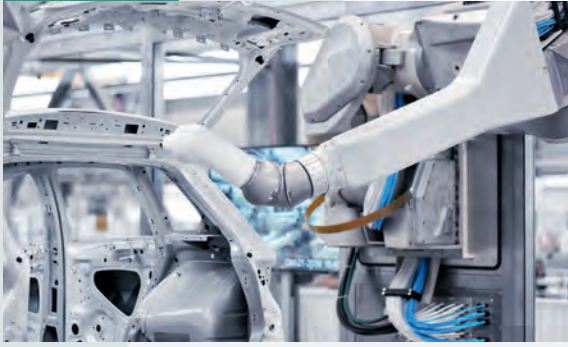

Photo: Durr AG

Handling



Foto: Vansichen Lineartechnik Belgium

Automation



Machine Tools



Packaging Machines



Additive Manufacturing



Materials Handling



Measuring Technology

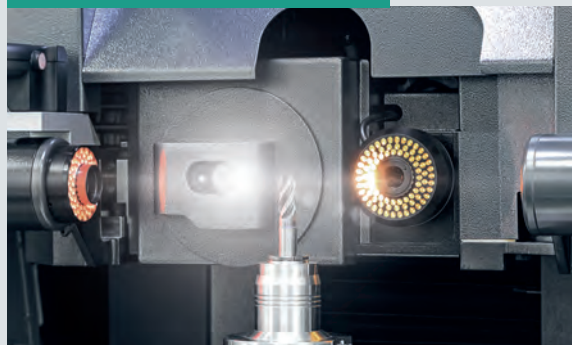

Photo: E. ZOLLER GmbH & Co. KG



INNOVATIVE SOLUTIONS FROM STANDARD TO CUSTOM

No matter what needs to be moved, we have the right solution for your application.

We are not just a manufacturer, innovative concepts and tailor-made solutions in drive technology are the challenges we face every day. We develop products in close cooperation with our customers so that we can find the ideal solution

for individual requirements. The latest technologies and the entire wealth of experience of the ATLANTA employees are always used to implement your wishes. All this makes us a premium supplier in drive technology and your reliable partner.



"If we at ATLANTA can do anything, it's custom solutions in drive technology"

Sven Geißler | Product Development Special Gearboxes

Custom Special Gear Units

Based on our series production, we develop and produce special gears according to individual customer specifications. With comprehensive know-how from all areas of drive technology, our engineers and technicians develop the basis for functionality, precision and reliability of special solutions for different branches of mechanical engineering. This results in innovative new developments of transmissions and individual components with the highest demands on quality and durability, a typical ATLANTA product.



Construction and Development



In our development department, individual drive technology solutions are developed every day. From individual components and equipment to complete product groups

Special Drive Elements



In addition to special gears, our delivery program includes special drive elements, which we manufacture according to customer drawings or ATLANTA design.

Gearing Technology



Due to the constant expansion of the production machines, we are able to process demanding parts according to customer specifications. We guarantee the highest quality and precision in gearing technology.

Product Range

Racks and Pinions

Welcome to the world's widest range of high-quality racks and pinions.

As a specialist in the field of high-quality racks we offer more than 350 types of racks. This is most comprehensive rack program that is currently available on the market. Our four gear rack classes **Ultra High Precision Rack**, **High Precision Rack**, **Precision Rack** and **Basic Rack** include the quality 5 to 10, in helical or straight toothed design, milled or hardened as well as hardened and ground and in sizes from module 1.5 to 12. For the realization of complete rack and pinion drives, we also offer a wide range of suitable gears, pinion shafts and lubrication systems.



Total pitch error
 $\leq 0,030$ mm



Tooth thickness tolerance
- 15 μ m



Feed force up to
max. 409 kN

Gear correction

optimally matched to the pinion and rack for perfect running properties

Special material according to ATLANTA specification

and hardening process optimally matched for the highest loads

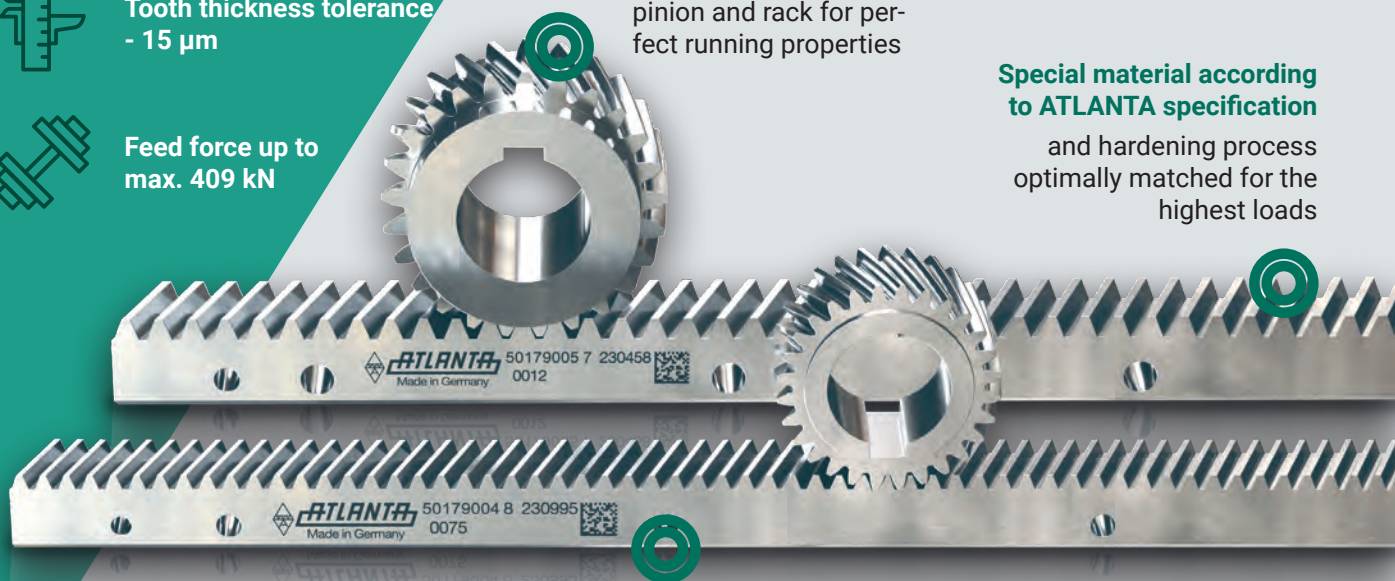

2D data matrix code
for reading the rack data
from the ATLANTA cloud



Features

- ✳ four classes of racks (UHPR, HPR, PR and BR)
- ✳ gearing quality 3 to 10
- ✳ module 1,5 to 12
- ✳ heat-treatable steel or case hardening steel according ATLANTA specification
- ✳ helical & straight toothed
- ✳ hardened & grounded (all sides grounded)
- ✳ length up to 2000 mm
- ✳ for each application the right rack
- ✳ industry related racks
- ✳ racks with 2D data matrix code

Unique Selling Points

- ✳ special material according to ATLANTA specification
- ✳ possibility to read product data by using the 2D matrix code
- ✳ designation with individual customer logo
- ✳ most modern calculation methods for the complete rack and pinion drive
- ✳ 100% quality control
- ✳ digital twin



ATLANTA Service

Start with ATLANTA and the world's first digital rack into the smart drive technology of tomorrow.

With the web-based tool, which requires no installation and can be used with all end devices, you can access the technical product data of ATLANTA racks at any time, as well as other applications such as Rack Mapping or requesting an identical Replacement Rack for your machine.

- ✳ product-specific information by using the 2D data matrix code
- ✳ rack mapping
- ✳ request „Digital Twin“



atlantagmbh.com/atlanta-service

Product Range

Servo-Worm Gear Units

Matching to our variety of high-quality racks we offer three different variants of servo angle gear units as precision gearboxes.

Our servo-worm gear units with low-backlash enjoy an excellent reputation worldwide. The three quality levels and different sizes enable a designer to select the required precision according to his requirements and budget. All servo angle gearboxes are available in the ATEX version and optionally with food graded oil.



Backlash
 ≤ 1 arcmin



max. output torque
up to 2200 Nm

Modular motor flange
for easy interchangeability
of servo motors

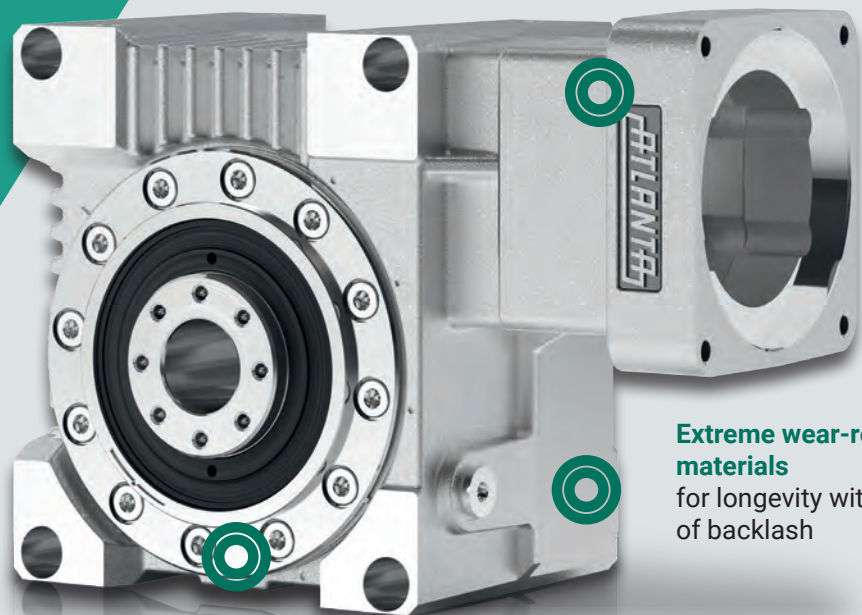

Extreme wear-resistant materials
for longevity without loss
of backlash

Special storage
for extremely small backlash such as
highest rigidity and highest precision



Features

- ✘ three variations (High Torque, High Performance and Economy)
- ✘ backlash <1 up to <5 arcmin
- ✘ 6 sizes (centre distance 32, 50, 63, 80, 100 and 125mm)
- ✘ 8 ratios 4,75 up to 52:1
- ✘ output: hollow shaft, with key or for clamp connection, with interface according EN ISO 9409-1-A
- ✘ highest rigidity, highest precision
- ✘ ATEX design available
- ✘ continuous operation possible (<80°C max.1500 rpm)
- ✘ available in variation with food grade oil

Unique Selling Points

- ✘ special storage
- ✘ extremely small backlash for servo worm gear units
- ✘ wear-resistant materials therefore no change in the backlash even after years of use
- ✘ easy interchangeability between the gearbox series
- ✘ very long know-how in the gear technology
- ✘ modular motor flange
- ✘ special couplings for motor gearbox connection, thus backlash-free gearbox and maximum power transmission

Lubrication Systems



Adequate lubrication is necessary to ensure consistent precision of the drive systems over the years. The flexible and user-friendly ATLANTA lubrication systems are used in almost all areas of drive technology worldwide.

- ✘ 4 different lubrication systems
- ✘ for single and multi-point lubrication
- ✘ felt lubrication pinion for an even supply of lubricant to the tooth flanks.
- ✘ individually adjustable emptying time up to 36 months
- ✘ up to 70 bar (1015 psi) delivery pressure for long supply routes
- ✘ power operation by battery, voltage supply 24V or via SPS

Product Range

Linear Actuators

ATLANTA linear actuators as linear motion drive are with their precision and robustness, the right drive concept for all dynamic lifting.

Our linear actuators are used wherever controllable lifting, lowering, feed, pressure, tilting or swiveling movements have to be carried out with the highest precision. It is irrelevant whether these are horizontal, vertical, pushing or pulling. With our high-performance screw jacks, high feed speeds are possible even with heavy loads. Compared to hydraulic lifting units, the combination of force and speed enables high dynamics and very precise positioning within the application.



Load capacity
up to 100 kN



Travelling speed
up to 666 mm/s



Input speed
up to 6000 min⁻¹

Heavy duty ball screw drive with high load capacity combine a long life with maximum precision

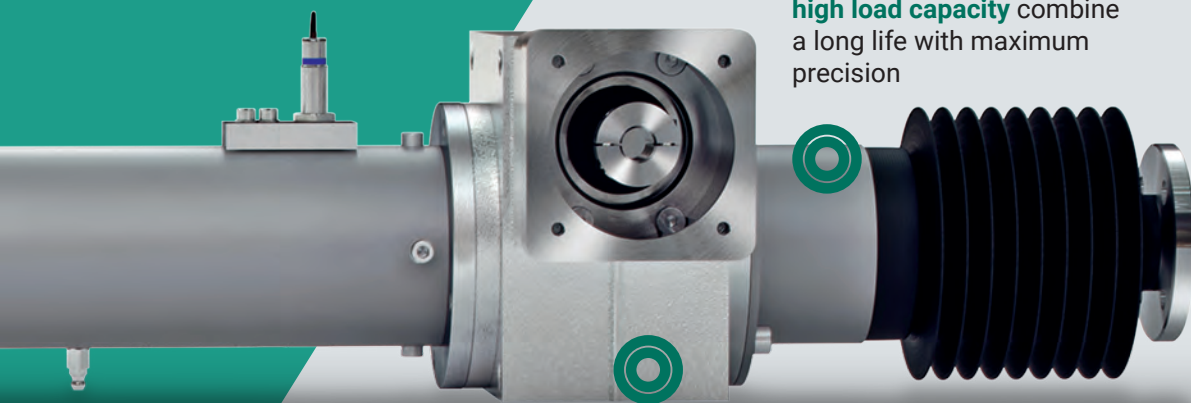

Servo-Worm Gear Unit
with special bearings to absorb the spindle and application forces



rotating version



lifting cylinder

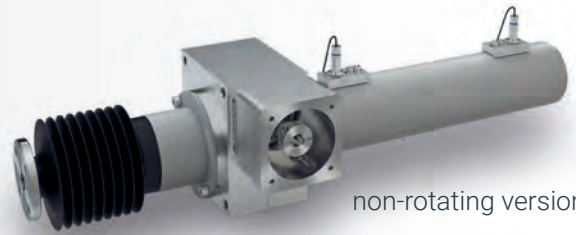

non-rotating version

Features

- ✦ three versions (rotating, non-rotating, lifting cylinder)
- ✦ 4 sizes
- ✦ load capacity up to 100 kN
- ✦ ball screw spindle drive with increased load
- ✦ operating with three-phase AC and servomotor
- ✦ connection to the central lubrication possible

Unique Selling Points

- ✦ travelling speed up to 666 mm/s
- ✦ input speed up to 6000 rpm
- ✦ duty cycle up to 100%
- ✦ highest lifetime
- ✦ special version for additive manufacturing



Linear Actuators for Special Applications

Wide expertise paired with creativity is our secret of success for special applications with our linear actuators. With many years of expertise, our specialist engineers take every aspect into account when developing lifting drives for special applications:

- ✦ ATEX
- ✦ food industry
- ✦ vacuum environment
- ✦ additive manufacturing
- ✦ outdoor use
- ✦ high temperature environment

Product Range

Special Gearboxes and Special Parts

With application-specific product developments, we prove again and again where our strengths lie. We support you right from the planning phase and accompany you throughout the entire product life cycle with our entire ATLANTA know-how.

Through close contact with our customers, we develop application-specific special gearboxes and special parts that require maximum functionality, precision and reliability in practical use. Our work does not end with the delivery of the desired product, we are more interested in a long-term partnership with our customers, where we use our strengths to your advantage and support you in the further development of your product right from the start.



special racks
module 1-16



pinions milled
up to Ø 900 mm

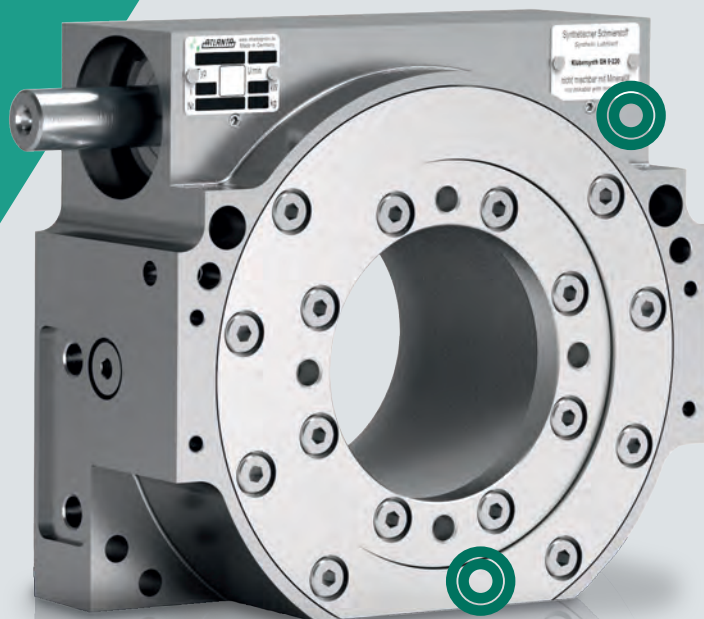

Customized design

housing and connection
dimensions according to
customer requirements

Selection of the components

individually according to customer
needs and application



Special Precision Gearboxes

- ✘ worm gear units
- ✘ spur gear units
- ✘ bevel gear units
- ✘ belt gear units
- ✘ planetary gear units
- ✘ spindle lifting gear units
- ✘ bevel helical gear units
- ✘ worm gear units with spur gear stage

Special Racks

- ✘ module 1 – 16
- ✘ gearing quality 3 – 10
- ✘ with milled or grounded flanks up to 2000mm length
- ✘ with special cross section
- ✘ made of different materials
- ✘ with customized surface finish

Special Gearings

- ✘ **Gear wheels and change gears**
with milled and grounded flanks up to module 8
- ✘ **Bevel gears**
with straight teeth, crowned acc. to Gleason up to module 5
- ✘ **Worm wheels and worms**
with milled or grounded flanks up to module 6
- ✘ **Internal gearings**
up to module 5



We already support you in the planning phase of your products with all our know-how. Together with you we create precise specifications for projects of all kinds

- ✘ Design and construction of precision gears and drive elements
- ✘ 3D model creation of individual parts or complete product groups
- ✘ Planning and development work including the corresponding elaboration
- ✘ Equipment design including manufacture of precision gears and individual components.



ATLANTA



ATLANTA Drive Systems Inc.

Phone: (800) 505-1715

Fax: (732) 282-0450

Email: info@atlantadrives.com

Web: www.atlantadrives.com

Our qualified employees are at your disposal for all questions, also in a personal conversation.

ATLANTA Antriebssysteme GmbH

Adolf-Heim-Straße 16
74321 Bietigheim-Bissingen

T +49 (0)7142 / 7001-0
F +49 (0)7142 / 7001-99

E info@atlantagmbh.de
W www.atlantagmbh.de

